

*



PURCHASE ORDER
MARIANO MARCOS STATE UNIVERSITY
 City of Batac 2906 Ilocos Norte

Supplier : REIGN GENERAL MERCHANDISE Address : Sarrat, Ilocos Norte TIN : 253-742-284-001	P.O. No. : 07308603-2021-09-550 Date : September 13, 2021 Mode of Procurement : NP-Small Value
--	--

Gentlemen:
 Please furnish this Office the following articles subject to the terms and conditions contained herein:
 PR No.: 2021-08-136 (07308603)- USAID-WARP

Place of Delivery : MMSU, City of Batac Date of Delivery : within 30 calendar days upon receipt of P.O.	Delivery Term : FOB Destination Payment Term : N/30
--	--

Stock/ Property No.	Unit	Description	Quantity	Unit Cost	Amount
	sets	150-L capacity SS Kettle and Column and other accessories (outsourced), pls. see attached	2	98,000.00	196,000.00
TOTAL					196,000.00

(Total Amount in Words): One Hundred Ninety Six Thousand Pesos Only

In case of failure to make the full delivery within the time specified above, a penalty of one-tenth (1/10) of one percent for every day of delay shall be imposed on the undelivered item/s.

Conforme:

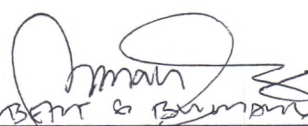

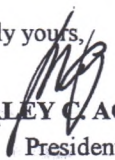
Signature over Printed Name of Supplier
09-21-21
 Date

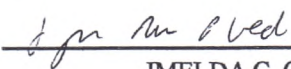
Very truly yours,

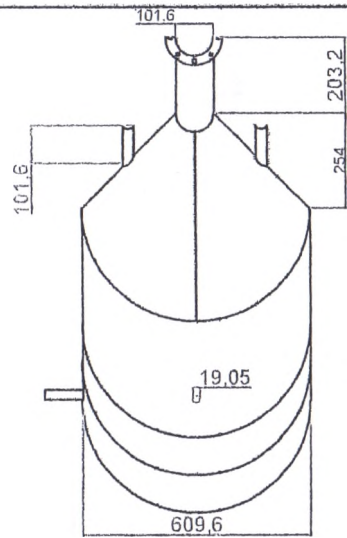
SHIRLEY C. AGRUPIS
 President

Fund Cluster : 07308603 Funds Available : _____  IMELDA C. CORPUZ Chief, Accounting Office	ORS/BURS No. : _____ Date of the ORS/BURS: _____ Amount : _____
--	--

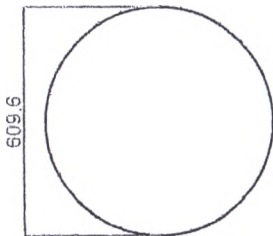

FRONT VIEW



BOTTOM VIEW

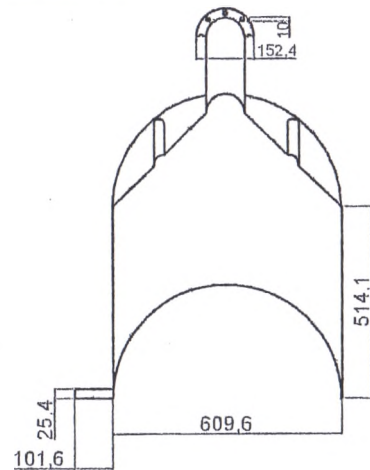

CUT VIEW

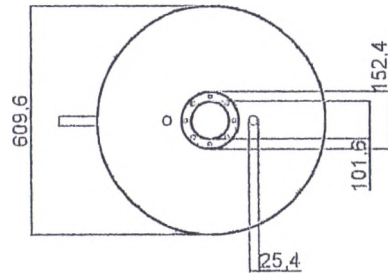

TOP VIEW

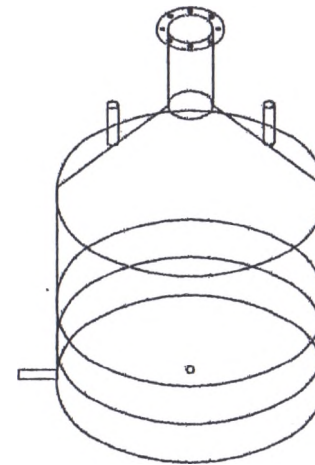

ISOMETRIC VIEW

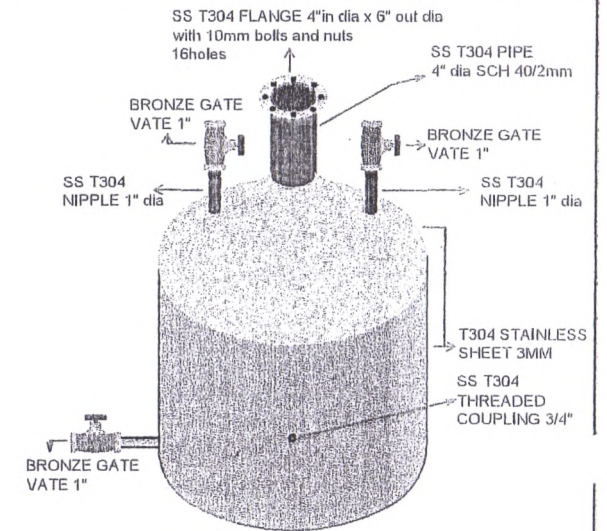

FRONT VIEW
 24"=609.6mm
 20.24"=514.1mm
 5"=127mm
 6"=152.4mm
 8"=203.2mm
 4"=101.6mm
 10"=254mm
 10mm

BOTTOM VIEW
 24"=609.6mm

TOP VIEW
 24"=609.6mm
 6"=152.4mm
 4"=101.6mm
 1"=25.4mm

150 LITERS
 CAPACITY

DESIGNED BY:	Janssen M. Sagadraca	PROJECT TITLE: 150-L CAPACITY DISTILLER EQUIPMENT KETTLE		
DRAWN BY:	Janssen M. Sagadraca			
CHECKED BY:				
APPROVED BY:				
		SIZE:	SHEET CONTENT:	REV

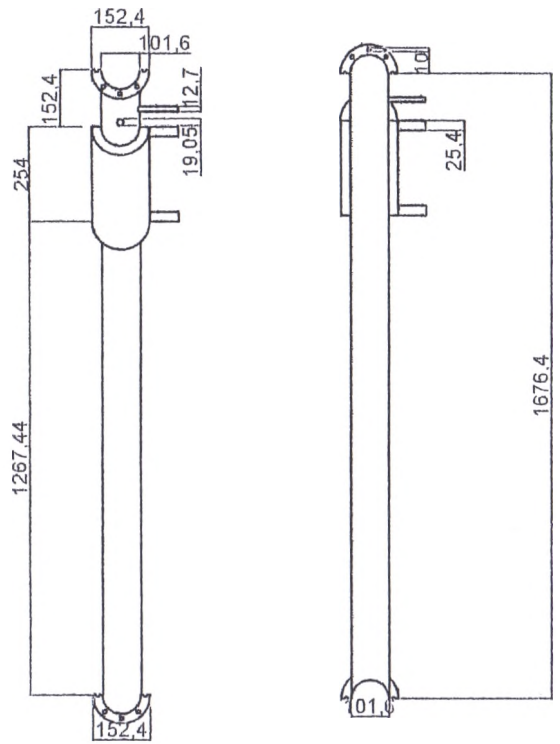

FRONT VIEW

CUT VIEW

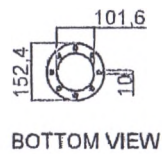

BOTTOM VIEW

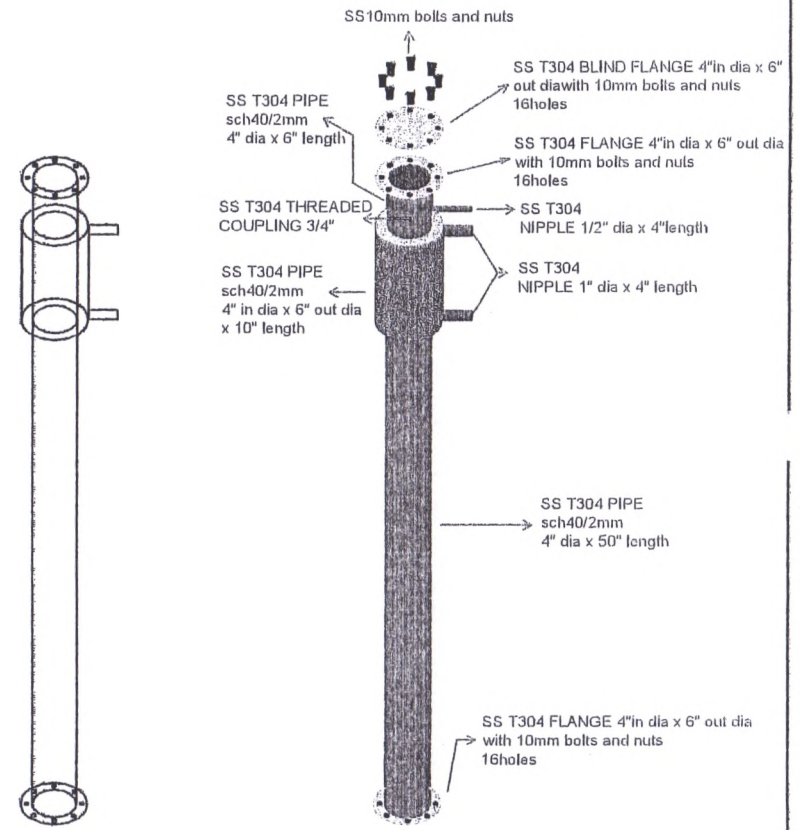

ISOMETRIC VIEW

FRONT VIEW
VIEW
6"=152.4mm
10"=254mm
4"=101.6mm
.75"=19.05mm
.5"=12.7mm

BOTTOM
6"=152.4mm
4"=101.6mm
10mm

DESIGNED BY:	Janssen M. Sagadraca
DRAWN BY:	Janssen M. Sagadraca
CHECKED BY:	
APPROVED BY:	

PROJECT TITLE:	150-L CAPACITY DISTILLER EQUIPMENT REFLUX COLUMN	
SIZE:		
		REV